

Valves

Actuated Heavy Duty Valves

Series III-L

Features

- ▶ Original Shear-Seal® technology
- ▶ 2 & 3 position valve
- ▶ 2 position actuated valve
- ▶ Manual override
- ▶ Air or hydraulic integrated actuator
- ▶ Superior shifting performance
- ▶ High flow with low pressure drop
- ▶ Rugged integrated solution
- ▶ Extended shaft for alternate position sensor
- ▶ Robust detent stop
- ▶ Panel mounting option
- ▶ Position indication option
- ▶ Suitable for hydraulic & water glycol media

Applications

- ▶ Land-based oil drilling controls
- ▶ BOP accumulator units
- ▶ Test systems
- ▶ Workover rigs
- ▶ Mobile drilling rigs

General Specifications*

Main Valve

Media Type:	Hydraulic oil or water based with stainless steel body
Working Pressure: 1" Size:	Hydraulic up to 3,000 or 5,000 psi (206 bar or 345 bar)
Back Pressure:	250 psi (17.2 bar) max at return port
Proof Pressure:	1.5x working pressure except at return port
Burst Pressure:	2x working pressure except at return port [3,000 psi (206 bar)]
Porting:	1" NPT standard Optional: SAE 16 (SAE J1926)
Media Temperature Range:	-30° to +185°F (-34.4° to +85°C)
Handle Detent:	All valves have 3-position detents for manual shift to center position
Wetted Materials: Body: Shaft: Rotor & Seals: Standard O-Rings:	Phosphate coated carbon steel or stainless steel option Stainless steel 400 series stainless steel Buna N Option: Viton®, Neoprene, EPR
External Materials: Housing: Hardware: Handle & Detent Disc:	Phosphate coated carbon steel Plated carbon steel Plated carbon steel
Flow Characteristics:	Cv Factor = 9.2 Capacity : 75 GPM @ 60ft/sec

Patent# US D686.298 S



Pilot Actuator

Working Pressure: Air:	Range: 80 to 120 psi (5.5 to 8.3 bar)
Hydraulic:	Range: 200 to 1,000 psi (13.8 to 68.9 bar)
Porting:	1/4"- 18 NPT
Media Temperature Range:	-30° to +185°F (-34.4° to +85°C)
Speed of Operation:	1/2 second or more for 90° throw to avoid damage (Restrict actuator flow to control speed)
Materials: Cylinder (Air/Hydraulic):	Hard anodized aluminum
End Plate:	Anodized aluminum
Hardware:	Plated carbon steel
Weight: (Valve & actuator)	48 lbs (21.8 kg) : pneumatic model 49 lbs (22.2 kg) : hydraulic model

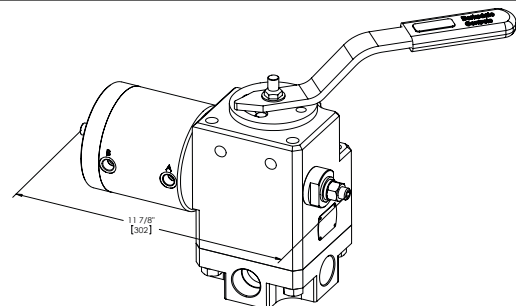

Series III-L

* See product configurator for additional options.

Actuated Heavy Duty Valves

Series III-L

Technical Drawings

2-Position Valve with Manual Override (Shown with Position Indicator Option)

Dimensions in inches [mm]

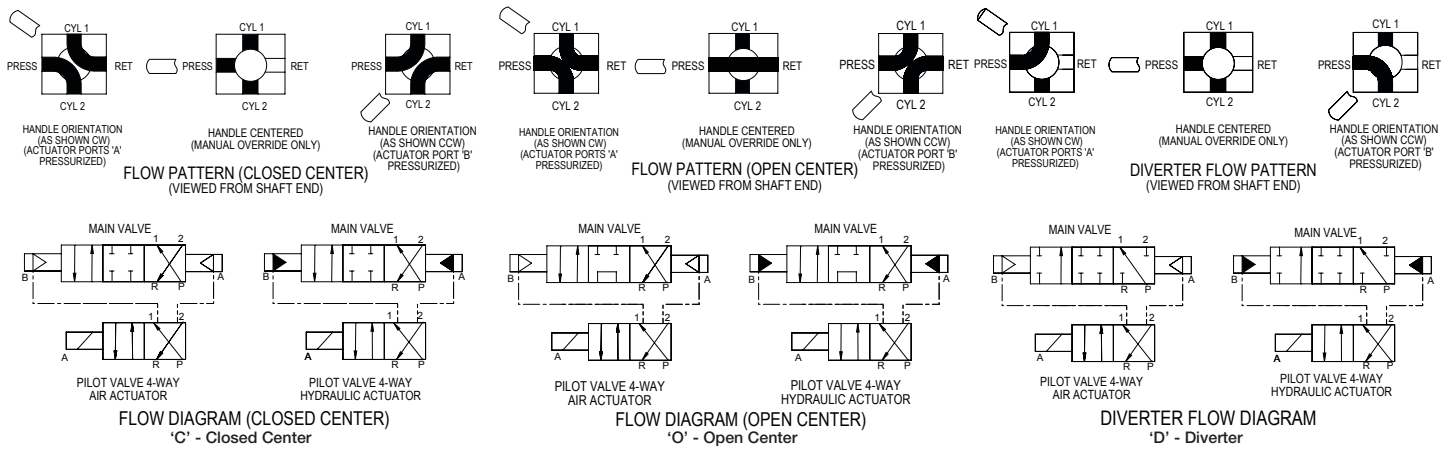
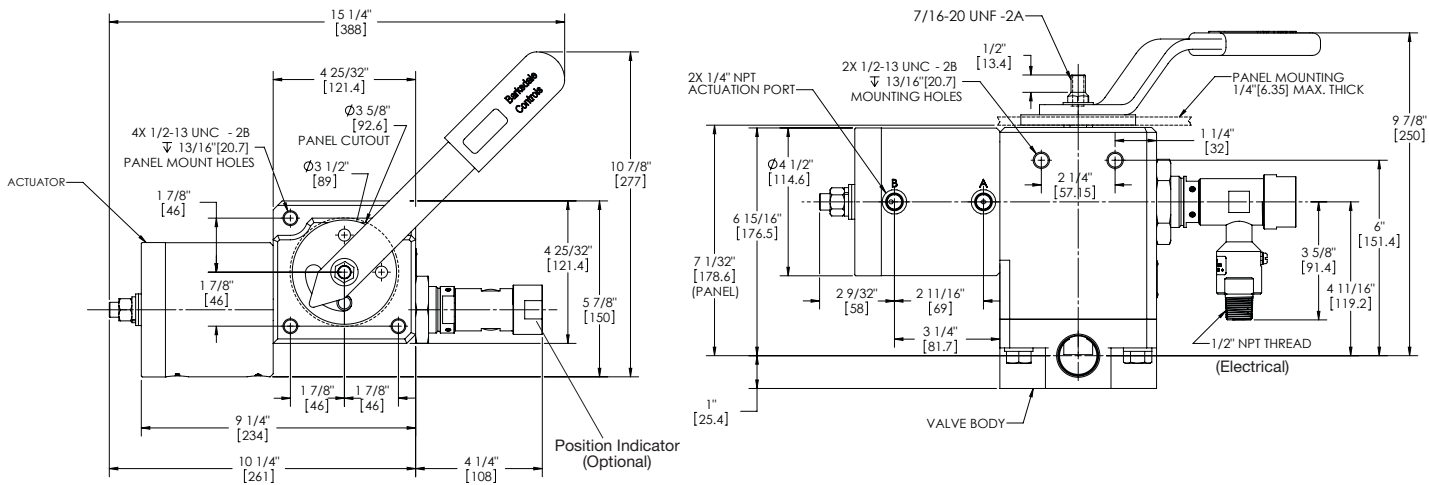

Product Configurator

Example: **L A 14 5 R 3 H C 2**

Series III Land _____

Actuation Type

A Air actuated cylinder

H Hydraulic actuated cylinder

Valve Series

14 4-way selector or diverter

Port Size

5 1" NPT (SAE Option)

Port Location

R Regular side porting

P Panel mount

Pressure Range

3 3,000 psi (206 bar)

5 5,000 psi (345 bar)

Working Media

H Hydraulic oil

W Lubricated water (with stainless steel body)

Flow Pattern

C Closed center (selector)

O Open center (tandem center) selector

D Diverter (bypass)

Seal Material Options

Blank Buna N (Standard)

-Z12 Neoprene

-Z13 Viton®

-Z15 EPR

Options

-B¹ Position indicator¹

-MS SAE J1926 porting

-US Approved countries material origin

-G 1/4" SAE gauge ports for CYL 1 & 2

-Z28² Stainless steel body

Position

2 2-position actuator, 90° rotation

Note: 1. Refer to Position Indicator Model 371MT7 datasheet
2. Stainless steel body is coated with baked enamel paint